

REV	DESCRIPTION	ECN #	CHG BY	DATE	APP'D
A	CONVERTED TO 3D/UPDATED PART NUMBER, WAS CSL	15548	RWK	2/18/19	EZR
B	UPDATED TO CURRENT STYLE	18198	NAS	01/23/20	JSR

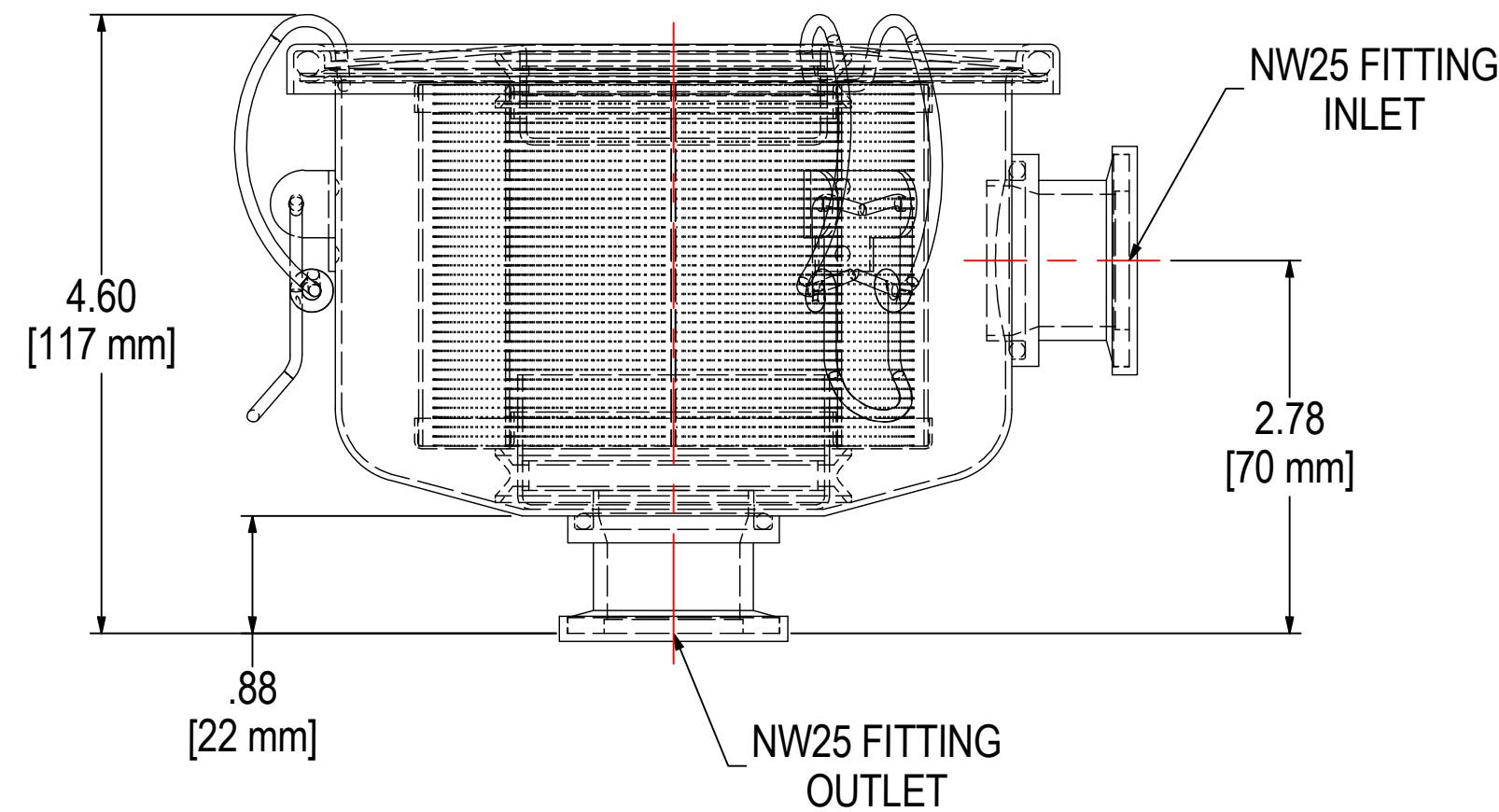
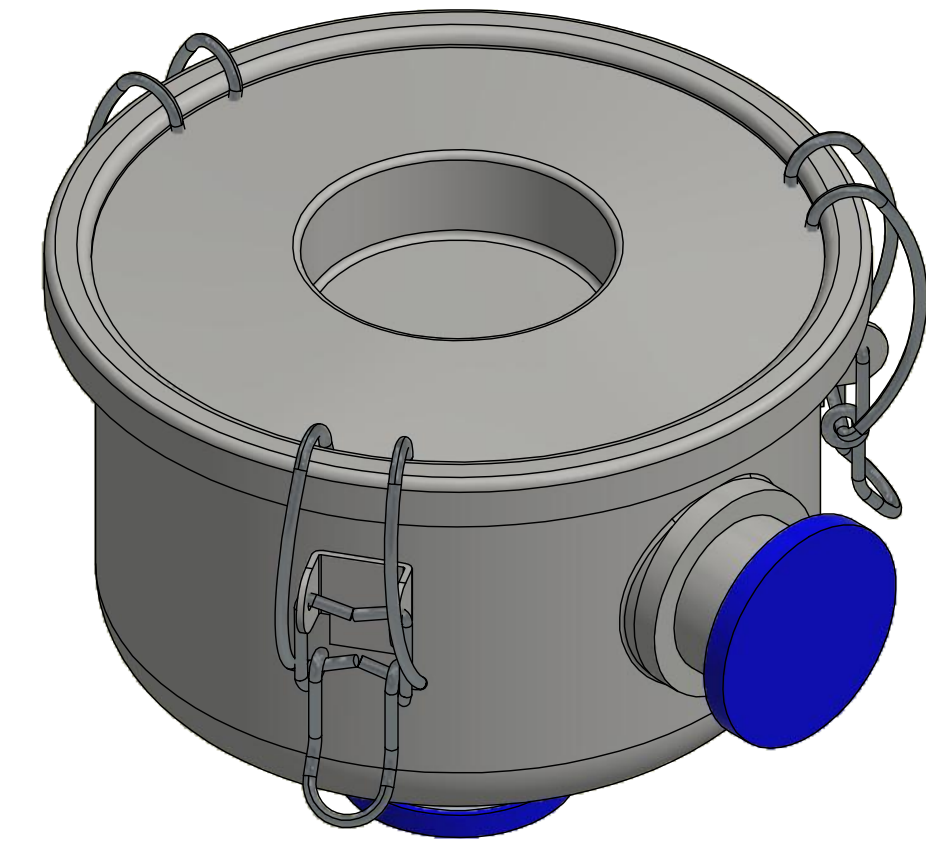
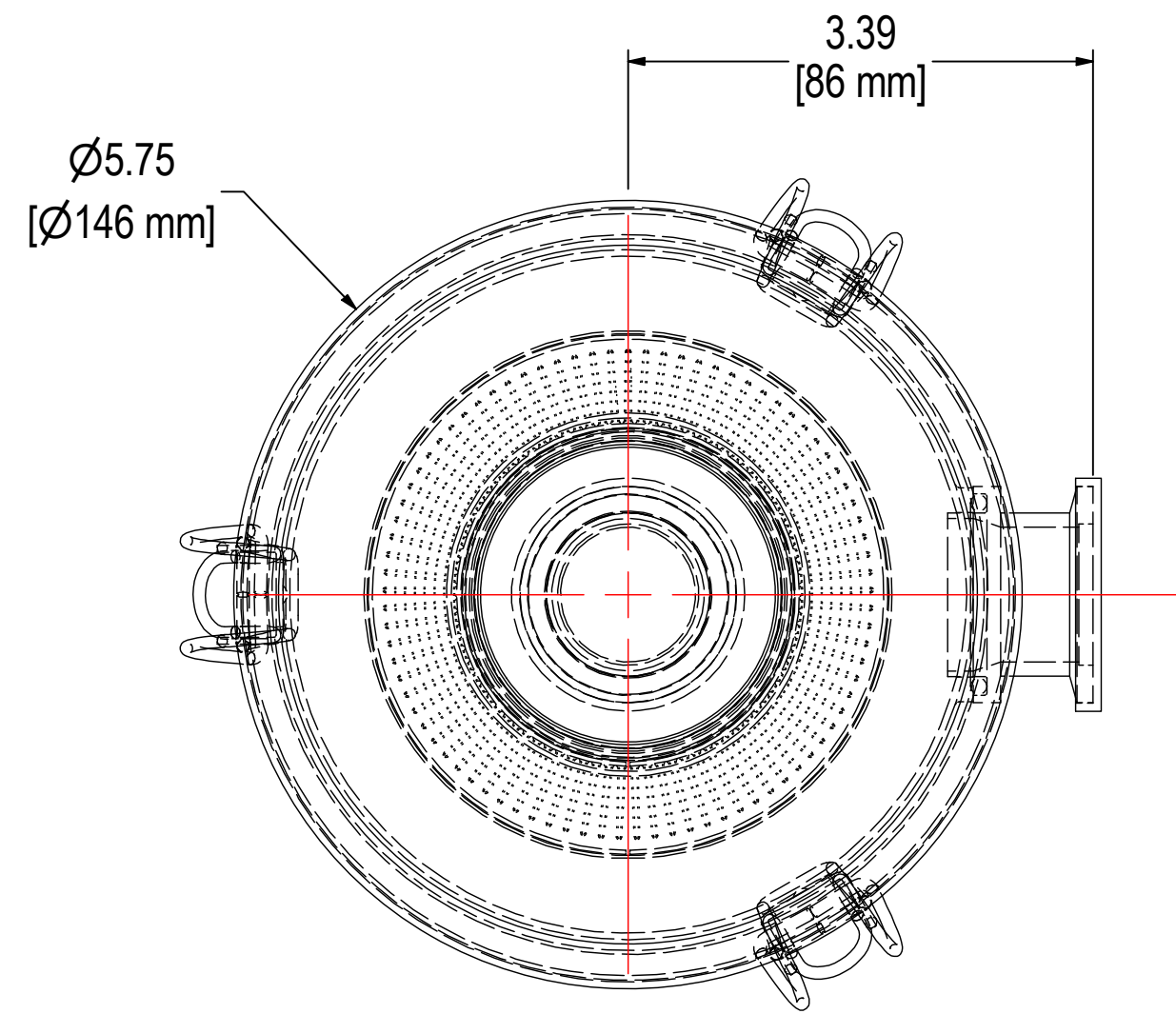

NOTES & SPECIFICATIONS:

1. FLANGES TO BE PROTECTED DURING PRODUCTION & SHIPMENT.
2. UNIT TO BE HELIUM LEAK TESTED TO 1×10^{-5} mbar L/s.

ELEMENT SPECS		
PART NUMBER	842	
MATERIAL	PAPER	
FLOW RATE	55 CFM	93 m ³ /hr
SURFACE AREA	1.5 ft ²	0.1 m ²
I.D.	2.38"	60mm
O.D.	3.88"	99mm
HEIGHT	2.75"	70mm

MODEL #: WL-842-NW25EN	MATERIAL: CARBON STEEL	FINISH: ELECTROLESS NICKEL	SHEET: 1 OF 1
MODEL NUMBER: WL-842-NW25EN			
DESCRIPTION: WL-842-NW25EN, ELECTROLESS NICKEL			
PROJECT: SD19011	DRAWN BY: EZR DATE: 2/1/2013	APPROVED BY: CRW DATE: 2/1/2013	REV: B